

PRO INSTALLER

16 Internal Affairs

What goes into making peak performing, great looking integral blinds?

22 Best of Bifolds

Alchemy compares 'old and new', bringing you the best of both.

37 Northern Sol

Yorkshire's top of the one-stop shops for installer support.

28 All Things AluSlide – in the CentreFold

Follow the arrows to experience uninterrupted views and effortless installations, built for the trade.

PRESTIGE PRODUCTS TRADE CUSTOMERS CAN TRUST

At BSW, we understand the needs of trade professionals. You require reliable products that perform well, look fantastic, and meet your clients' expectations. From their precision engineering and slim sightlines to their superior energy efficiency and durability, Sheerline's Prestige bi-fold doors are designed with the trade in mind.

As your trusted supplier, BSW ensures that you receive top-quality products on time and within budget. We offer exceptional customer service, guiding you through the process from product selection to aftercare. This partnership enables you to confidently deliver the best to your clients, whether you're working on high-end residential homes or large-scale commercial developments.

Precision, Performance, and Style

The Sheerline Prestige bi-fold door range is a top choice for those looking to offer high-quality, premium products to their clients. These aluminium doors are designed with a focus on delivering both impressive aesthetics and advanced performance. Whether your project involves new builds or renovations, Sheerline bi-fold doors provide the perfect solution.

One of the standout features of Sheerline bi-fold doors is their ultra-slim sightlines. This sleek profile maximises the glass area, providing expansive views and allowing natural light to flood into interior spaces. Trade professionals working on projects where visual appeal is a priority will ap-



preciate the impact these doors can have on the overall design. Whether it's a residential home looking to create a seamless indoor-outdoor flow or a commercial building that demands a sophisticated finish, Sheerline bi-fold doors deliver a striking first impression.

Energy Efficiency at its Best

In today's market, energy efficiency is non-negotiable. The Sheerline Prestige range excels in this area, achieving U-values as low as 1.4 W/m²K, making them a great option for projects prioritising thermal performance. Sheerline's unique Thermlock® technology ensures that these aluminium doors provide excellent insulation, helping your customers save on energy costs while meeting building regulations.

With growing environmental concerns, many clients are looking for sustainable options. Sheerline bi-fold doors are not only energy-efficient but also manufactured

with sustainability in mind, making them a strong choice for eco-conscious projects. This commitment to performance without sacrificing environmental responsibility gives you, as a trade professional, a key selling point for clients who are serious about sustainability.

Durability and Low Maintenance

When it comes to materials, aluminium stands out for its strength and durability, and Sheerline's Prestige bi-fold doors are no exception. These doors are designed to withstand the test of time, making them ideal for projects where long-term performance is a priority. Aluminium is inherently robust and resistant to warping, rust, and corrosion, meaning the doors will maintain their quality and appearance even in harsh weather conditions.

The doors are powder-coated for a long-lasting finish, ensuring

NOVEMBER 2024 // ISSUE 140

PROINSTALLER.CO.UK FREE



Cortizo 4700 sliding doors featuring KORNICHE TECHNOLOGY

- Fast & simple glazing with the unique patented **KORNICHE SpeedBead**
- Easy one drop delivery with glass & door - Sash up to 2.5m direct to site
- Double & triple glazing
- Pre-assembled doors
- Slim interlock
- PAS24 Security as standard
- 10 year warranty



4000 x 2000 4 sash, anthracite grey, unglazed, delivered from only

£550
PER LEAF +VAT*

ADD GLASS

4mm from **£55** per sqm?
6mm from **£78** per sqm?



MADE FOR TRADE



Contact us for a Kwikquote today!

madefortrade.co
sales@madefortrade.co
01642 610799

SCAN THE QR CODE FOR



20%
FIRST ORDER DISCOUNT!

* Discount applies to all trade customers and is applied to the first, single item purchase of Cortizo 4700 Slides | Door price based on 4000 x 2000, 4 sash, anthracite grey, unglazed, no sill, no vents, no reinforcement. | Door and Glass prices include delivery, postcode restrictions apply. Prices are correct at point of publishing and may be subject to change.

Continues on page 02

M. MARCUS R500 SPI LOCKING SYSTEM: 'A BEACON OF INNOVATION AND RELIABILITY'

The R500 SPI cylinder is engi-

neered with a host of features that make it a formidable barrier against unauthorised access. It boasts a patented reversible key system, which not only enhances convenience but also significantly boosts security. The cylinder is equipped with six encryption pins in the inferior line, up to four pins in the lateral line, and up to five pins in the superior line, all made from wear-resistant special brass. This intricate pin configuration ensures that the lock is highly resistant to picking and other forms of tampering.

Additionally, the R500 SPI includes integrated drilling protection, with hardened steel pins in both the cylinder body and plug. This feature is crucial in preventing forced entry attempts, making it an ideal choice for high-security applications such as armoured doors.

One of the standout aspects of the R500 SPI cylinder is its versatility. It is available in both compact and modular designs, catering to a wide range of installation requirements. Whether you need a single profile cylinder, a double profile cylinder, or a cylinder and turn, the R500 SPI has you covered. Moreover, it can be customised with various key options, including key different and key alike versions, making it suitable for complex master key systems.

The cylinder's adaptability extends to its aesthetic options as well. It comes in a standard matt nickel-plated or brass finish, with keys available in multiple colours, allowing for a personalised touch that can match the decor of any property.

ISEO has ensured that the R500 SPI cylinder meets rigorous international standards. It complies with the DIN EN 1303:



2015-08 certification, which attests to its durability, security, and performance. This certification is a mark of quality that provides peace of mind to users, knowing that their security solution is both reliable and recognised globally.

Special Pin Inserted

In the R500 SPI system, the exclusive Special Pin Inserted design works together with specially shaped pins in the cylinder and cylinder body to give the system the highest level of security.

Cylinder

The cylinder is equipped with two elements that are in one of the chambers: the Double Action Pin and the Special Top Pin. These two elements interact with the corresponding key.

Key

The key of this system is based on a branded new profile and it is equipped with an innovative SPI pin, which is present on both sides of the key in the respective coding row. The pin SPI acts as an anti-duplication device.



Patented Until 2036

The ISEO R500 SPI cylinder is patented until 2036. This long-term patent protection ensures that the unique security features and innovative design of the R500 SPI remain exclusive to ISEO, providing users with a high level of security and peace of mind for many years to come.

- Made In Italy. Quality European Manufacturer
- Differ, Master keyed or Keyed alike cylinders provided with two keys included
- Cylinder body & plug made of brass matt nickel-plated
- Suitable for installation in fire doors
- Encryption pins in stainless steel
- Locking cam made of sintered steel
- In each plug there are two picking-resistant counter pins
- The drilling protection consists of hardened steel pin in the cylinder body and plug
- Patented SPI pin
- Grade 6 security
- Patented until 2036

Key Features of M. Marcus Master Keying Systems

- 1. Versatility:** M. Marcus master key systems can be tailored to different types of buildings, whether it's a single-family home, a multi-family residential building, or a large commercial complex.
- 2. Sub-Groups:** The master key system can be divided into sub-groups, which helps in organising and managing access more efficiently. This feature is beneficial for buildings with different levels of access requirements, such as offices, schools, or hospitals.



3. Security and Reliability: M. Marcus and ISEO products are known for their high-quality materials and robust construction, ensuring long-term reliability and security.

4. Customisation: The systems can be customised to meet specific needs, including different key profiles and finishes to match the aesthetic requirements of the property.

With the ISEO specialised cylinder pinning department, where M. Marcus could produce a full range of master key suites. In such a specialised industry, staff retention is essential to ensure a skilled and knowledgeable team, and the company has many longstanding members of staff, evidence of the family-run mentality that remains at the heart of its ethos today. With the lead time for master keying now at a three to five-day turn around (even on high security patent protected ranges), with next day service also, being an option, which has proven to be a huge selling point for the company.

Branded in a sleek, contemporary design, it comprises of an assembly office where master key suites are written and pinned by fulltime experienced pinners, a key cutting room with computerised machinery, as well as a sales office for the team of dedicated ISEO sales staff and finally meeting rooms and showrooms.

For further details or for any enquiries please contact the M. Marcus Security sales office: 01384 457900 OPTION 3. www.m-marcus.com



ISEO®

ULTIMATE ACCESS TECHNOLOGIES

R500 SPI

PATENTED

M. Marcus Ltd introduces the **ISEO** innovative R500 SPI locking system.

Designed and patented in accordance with the highest security standards.

- Made In Italy. Quality European Manufacturer
- Differ, Master keyed or Keyed alike cylinders provided with 2 keys included
- Cylinder body & plug made of brass matt nickel-plated
- Suitable for installation in fire doors
- Encryption pins in stainless steel
- Locking cam made of sintered steel
- In each plug there are 2 picking-resistant counter pins
- The drilling protection consists of hardened steel pin in the cylinder body and plug
- Patented SPI pin
- Grade 6 security
- Patented until 2036



Patented
until 2036

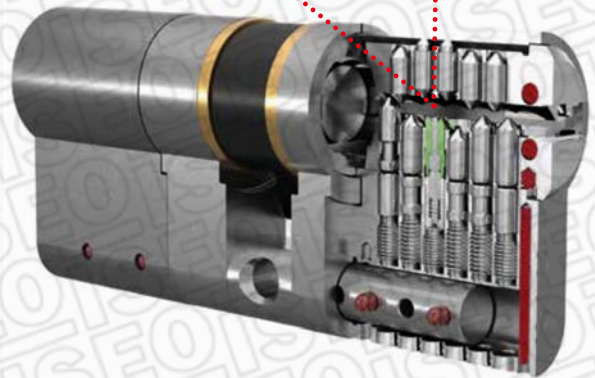

presented by



m.marcus
architectural hardware

M. Marcus Limited
Unit 7, Narrowboat Way,
Dudley, West Midlands,
DY2 0XQ

Tel: 01384 457900

Fax: 01384 253687

Web: www.m-marcus.com

Email: iseosales@m-marcus.com



BS ENI 303 BS ENI 303
TS007-1:2014+A2:2018
KM 544418